

# OPERATION AND MAINTENANCE MANUAL

for

**MODEL W100-3**  
1500 lb HAND WINCH

**MODEL W100-6**  
1500lb HAND WINCH

**MODEL W200-5**  
1500lb HAND WINCH

**MODEL W100-3P\***  
1500 lb HAND WINCH  
750 lb CAPACITY  
WITH  
POWER OPERATION

**MODEL W100-6P\***  
1500 lb HAND WINCH  
750 lb CAPACITY  
WITH  
POWER OPERATION

**MODEL W200-5P\***  
3000 lb HAND WINCH  
1500 lb CAPACITY  
WITH  
POWER OPERATION

(Dwg.MHTPAOOS)

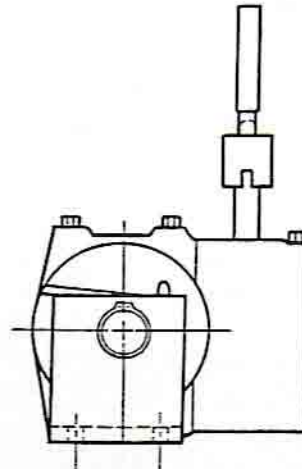
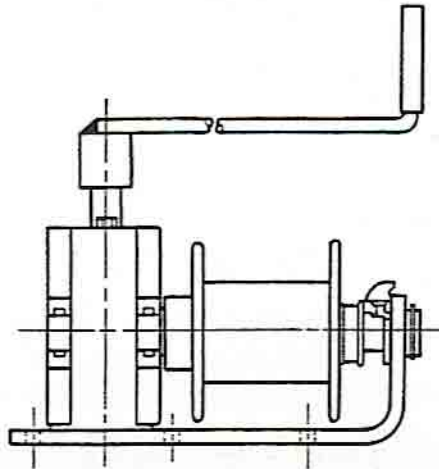

\* 'P' designates winch may be used with power, reducing rated capacity by 50%. Use intermittent power only. See 'OPERATION' for duty cycle. Motor is customer-provided.

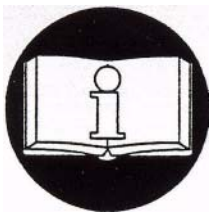

**READ THIS MANUAL BEFORE USING THESE PRODUCTS.** This manual contains important safety, installation, operation and maintenance information. Make this manual available to all persons responsible for the operation, installation and maintenance of these products.

**WARNING**

Do not use this winch for lifting, supporting, or transporting people or lifting or supporting loads over people.

Always operate, inspect and maintain this winch in accordance with American National Standards Institute Safety Code (ANSI B30.7) and any other applicable safety codes and regulations.

Refer all communications to Wintech International Inc. or your nearest Distributor.



# TABLE OF CONTENTS

Description	Page No.
<b>Safety Information</b>	
Danger, Caution, Warning and Notice .....	3
Safety Summary .....	3
Safe Operating Instructions .....	4
Warning Labels .....	4
<b>Specifications</b>	
Line Pull and Drum Wire Rope Capacities .....	5
<b>Installation</b>	
Mounting .....	5
Wire Rope Selection .....	6
Installing Wire Rope .....	6
<b>Operation</b>	
Handle Attachment .....	7
Paying Out or Hauling In with Handle .....	7
Power Operation .....	7
<b>Inspection</b>	
Frequent Inspection .....	8
Periodic Inspection .....	8
Testing .....	9
<b>Lubrication</b>	
Enclosed Gears .....	9
Wire Rope .....	9
<b>Maintenance</b>	
General .....	9
Gear Housing Removal .....	10
Gear Housing Disassembly .....	10
Gear Housing Assembly .....	10
Gear Housing Installation .....	10
Drum Keeper Replacement .....	11
Gear Housing Removal (Power Operation) .....	11
Gear Housing Disassembly (Power Operation) .....	11
Gear Housing Assembly (Power Operation) .....	11
Gear Housing Installation (Power Operation) .....	12
Brake Disc Removal .....	12
<b>Assembly Drawing and Parts List</b>	
Winch Assembly Drawing .....	13
Winch Assembly Parts List .....	14
<b>Parts Ordering Information</b>	
Return Goods Policy .....	15
<b>Warranty</b>	
Limited Warranty .....	16
<b>Office Locations</b>	
Locations .....	17

## SAFETY INFORMATION

This manual provides important information for all personnel involved with the safe installation, operation and proper maintenance of this product. Even if you feel you are familiar with this or similar equipment, you must read and understand this manual before operating the product.

### Danger, Warning, Caution and Notice

Throughout this manual there are steps and procedures which, if not followed, may result in a hazard. The following signal words are used to identify the level of potential hazard.

#### DANGER

Danger is used to indicate the presence of a hazard which *will* cause *severe* personal injury, death, or substantial property damage if the warning is ignored.

#### WARNING

Warning is used to indicate the presence of a hazard which *can* cause *severe* personal injury, death, or substantial property damage if the warning is ignored.

#### CAUTION

Caution is used to indicate the presence of a hazard which *will* or *can* cause *minor* personal injury or property damage if the warning is ignored.

#### NOTICE

Notice is used to notify people of installation, operation, or maintenance information which is important but not hazard-related.

### Safety Summary

#### WARNING

**Do not use this winch for lifting, supporting, or transporting people or lifting or supporting loads over people.**

**The supporting structures and load-attaching devices used in conjunction with this winch must provide an adequate safety factor to handle the rated load, plus the weight of the winch and attached equipment. This is the customer's responsibility. If in doubt, consult a qualified structural engineer.**

**Always maintain at least three full wraps of wire rope on the drum.**

**Power must be used only intermittently on W100-3P, W100-6P and W200-5P. See "OPERATION" section. Operation with power is the sole responsibility of the user. Do not convert units W100-3, W100-6 and W200-5 to power operation.**

The National Safety Council, Accident Prevention Manual for Industrial Operations, Eighth Edition and other recognized safety sources make a common point: Employees who work near cranes or assist in hooking on or arranging a load should be instructed to keep out from under the load. From a safety standpoint, one factor is paramount: conduct all lifting operations in such a manner that if there were an equipment failure, no personnel would be injured. This means keep out from under a raised load and keep out of the line of force of any load.

To the best of our knowledge, WINTECH INTERNATIONAL winches are manufactured in accordance with the latest standards in effect at time of manufacture.

However, contrary to common belief, the Occupational Safety and Health Act of 1970, as we understand it, generally places the burden of compliance with the user, not the manufacturer. Many OSHA requirements are not concerned or connected with the manufactured product but are, rather, connected with the final installation: "It is the owner's responsibility and user's responsibility to determine the suitability of a product for any particular use. Check all applicable industry, trade association, federal, state and local regulations. Read all operating instructions and warnings before operation."

**Rigging:** It is the responsibility of the operator to exercise caution, use common sense and be familiar with proper rigging techniques. See ANSI/ASME B30.9 for rigging information, American National Standards Institute, 1430 Broadway, New York, NY 10018.

#### NOTICE

**Using other than genuine WINTECH INTERNATIONAL parts will result in the void of warranty.**

## SAFE OPERATING INSTRUCTIONS

The following warnings and operating instructions have been adapted in part from American National (Safety) Standard ANSI B30.7 and are intended to avoid unsafe operating practices which might lead to personal injury or property damage.

**WINTECH International** recognizes that most companies who use winches have a safety program in force. In the event that some conflict exists between a rule set forth in this publication and a similar rule already set by an individual company, the more stringent of the two should take precedence.

Safe Operating Instructions are provided to make an operator aware of dangerous practices to avoid and are not necessarily limited to the following list. Refer to specific sections in the manual for additional safety information.

1. Only allow personnel instructed in safety and operation of this winch to operate and maintain the winch.
2. Only operate a winch if you are physically fit to do so.
3. When a "DO NOT OPERATE" sign is placed on the winch, do not operate the winch until the sign has been removed by designated personnel.
4. Before each shift, check the winch for wear and damage. Never use a winch that inspection indicates is worn or damaged.
5. Never lift a load greater than the rated capacity of the winch. See warning labels and tags attached to winch.
6. Keep hands, clothing, etc., clear of moving parts.
7. Never place your hand in the throat area of a hook or near wire rope spooling onto or off of the winch drum.
8. Always rig loads properly and carefully.
9. Be certain the load is properly seated in the saddle of the hook. Do not tiplod the hook as this leads to spreading and eventual failure of the hook.
10. Do not "side pull" or "yard".
11. Make sure everyone is clear of the load path. Do not lift a load over people.
12. Never use the winch for lifting or lowering people, and never allow anyone to stand on a suspended load.
13. Ease the slack out of the wire rope when taking-up wire rope. Do not jerk the load.
14. Do not swing a suspended load.
15. Never suspend a load for an extended period of time.
16. Never leave a suspended load unattended.
17. Pay attention to the load at all times when operating the winch.
18. After use, properly secure winch and all loads.
19. The operator must maintain an unobstructed view of the load at all times.
20. Never use the wire rope as a sling.

## WARNING LABELS

Each winch is supplied from the factory with the warning label shown. If the label is not attached to your unit, order a new label and install it. See the parts list for the part number. Read and obey all warnings and other safety information attached to this winch. Label may not be shown actual size.

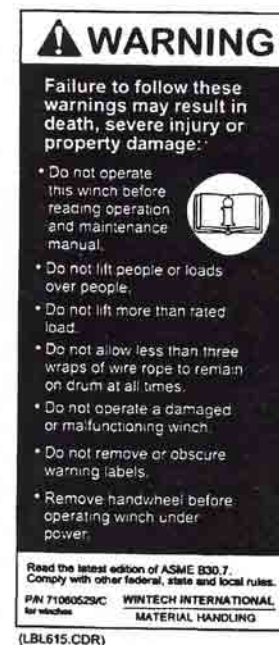

## SPECIFICATIONS

### WINCH MODEL

DRUM SIZE:	W100-3		W100-6		W200-5	
	(ins)	(mm)	(ins)	(mm)	(ins)	(mm)
<b>Barrrel Diameter</b>	2.375	60	2.375	60	4.0	102
<b>Flange Diameter</b>	4.375	111	4.375	111	7.0	178
<b>Distance Between Flanges</b>	3.0	76	6.0	152	5.0	127

Model No.	Line Pull 1st layer (lbs)	Gear Ratio	1/8"	Drum Capacities (ft)			Net wt**	
				3/16"	1/4"	5/16"	(lbs)	(kgs)
W100-3	1500							
W100-3P*	750	20:1	120	60	34	-	20	9.1
W100-6	1500							
W100-6P*	750	20:1	240	120	67	-	21	9.5
W200-5	3000							
W200-5P*	1500	30:1	560	253	135	96	48	21.8

\* P indicates unit may be powered intermittently, motor not supplied.

\*\* Winch without wire rope.

## INSTALLATION

### Mounting

- Mount the winch on a ridged surface which is capable of supporting the winch and will prevent deflecting or distortion of the winch under maximum load.
- Choose a site that uses as short a line as practical.
- For models W100-3P, W100-6P and W200-5P only. Ensure the wire rope is installed to inhaul when the worm shaft (4, Winch Assembly Drawing) rotates counterclockwise. See Dwg MHTPA0011.
- When a lead sheave is used, it must be aligned with the center of the drum. The diameter of the lead sheave must be at least 18 times the diameter of the wire rope.
- Maintain a fleet angle between the sheave and winch of no more than 1-1/2 degrees. For every inch of drum length, the lead sheave must be at least 1.6 feet (0.5 m) from the drum.
- Make sure the mounting surface is flat to within 1/16 in. (2 mm). Shim if necessary.
- Position the winch. The handle rotation must be a full 360 degrees unobstructed. Reposition winch if necessary.
- Mounting bolts or screws must be 3/8 in. diameter (10 mm) on W100 models and 1/2 in. diameter (12 mm) on W200 models and be Grade 8 or better. Use self-locking nuts or nuts with lock washers.
- Tighten mounting bolts evenly and torque to 30 lb.ft. (40N-m) dry. If the fasteners are plated, lubricated or a thread locking compound is used torque to 23 lb.ft. (31N-m).

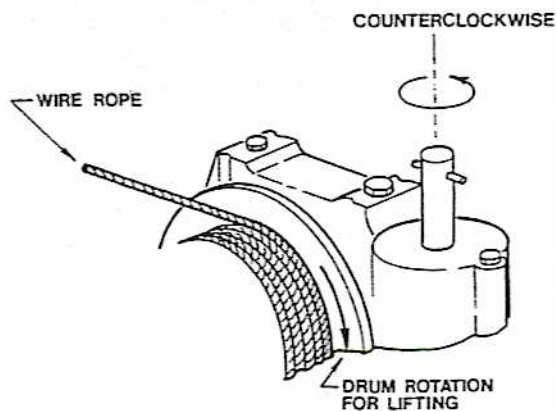

(Dwg. MHTPA0011)

### Safe Installation Procedures

- Do not use wire rope as a ground for welding.
- Do not weld to the winch or attach a welding electrode to the winch or wire rope.
- Never run the wire rope over a sharp edge. Use a correctly sized sheave. See instruction 4 under "Mounting".

### Bolt Pattern Dimension

Model No.	"A" in. (mm)	"B" in. (mm)	"C" in. (mm)	"D" in. (mm)
W100-3P	2-1/2 57	3-1/4 83	3-1/4 83	13/32 10
W100-6	2-1/2 57	3-1/4 83	6-1/4 159	13/32 10
W100-6P	2-1/2 57	3-1/4 83	6-1/4 159	13/32 10
W200-5	4 102	3-1/4 83	6 152	17/32 13
W200-5P	4 102	3-1/4 83	6 152	17/32 13

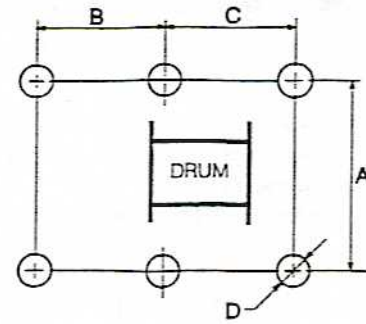

(Dwg. MHTPA0053)

### Wire Rope

#### ⚠ CAUTION

- Maintain at least 3 wraps of wire rope on the drum at all times.
- Install the wire rope to come off the drum in an over-wind position as indicated on the direction of rotation tag.

### Wire Rope Selection

Consult a reputable wire rope manufacturer or distributor for assistance in selecting the appropriate type and size of wire rope and, where necessary, a protective coating. Use a wire rope which provides an adequate safety factor to handle the actual working load and meets all applicable industry, trade association, federal, state and local regulations.

When considering wire rope requirements the actual working load must include not only the static or dead load but also loads resulting from acceleration, retardation and shock load. Consideration must also be given to the size of the winch wire rope drum, sheaves and method of reeving.

#### ⚠ WARNING

- Minimum wire rope diameter may not provide adequate safety factor.

### Wire Rope Diameter

Model No.	Minimum in.	(mm)	Maximum in.	(mm)
W100-3	1/8	3	1/4	6
W100-3P	1/8	3	1/4	6
W100-6	1/8	3	1/4	6
W100-6P	1/8	3	1/4	6
W200-5	1/8	3	5/16	8
W200-5P	1/8	3	5/16	8

### Installing Wire Rope

#### ⚠ CAUTION

- Position the wire rope so that it comes off the top of the drum, opposite the mounting base.

1. Cut wire rope to length and fuse end to prevent fraying of strands in accordance with the wire rope manufacturers instructions.

2. Feed the fused end of the wire rope into the wire rope anchor hole, past the anchor screw, and position the end just beneath the drum surface. See Dwg. MHTPA0070.

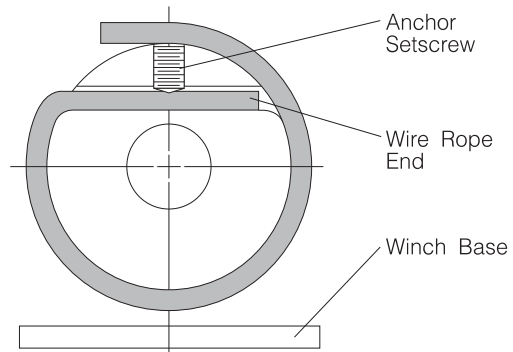

(Dwg. MHTPA0070)

3. Secure by tightening anchor screw. Make sure anchor screw is below the surface of the drum when tightened.
2. While keeping the wire rope under tension, spool it onto the drum.

### Cable Spooling

To allow for uneven spooling and decrease in line pull capacity as the drum fills up, use as short a wire rope as practical. To rewind wire rope apply tension to eliminate slack. This helps achieve level winding and tight spooling.

### Rigging

Make sure all wire rope blocks, tackle and fastenings have sufficient safety margin to handle the required load. Do not allow wire rope to contact sharp edges or make sharp bends which will cause damage to wire rope, use a sheave. Refer to wire rope manufacturers handbook for proper sizing, use and care of wire rope.

### Safe Wire Rope Handling Procedures

1. Always use gloves when handling wire rope.
2. Never use wire rope which is frayed or kinked.
3. Never use wire rope as a sling.
4. Always maintain at least three full wraps of wire rope on the drum.
5. Always ensure wire rope is correctly spooled and first layer is tight.

# OPERATION

The four most important aspects of winch operation are:

1. Follow all safety instructions when operating the winch.
2. Allow only qualified people to operate the winch.
3. Subject each winch to a regular inspection and maintenance procedure.
4. Be aware of the winch capacity and weight of load at all times.

## Handle Attachement

(See Winch Assembly Drawing MHTPC0010)

Align groove in handle (8) with drive pin (20) in worm shaft (4). Press handle (8) down until drive pin (20) is seated at root of handle groove. Insert cotter pin (31) through hole in handle (8) and worm shaft (4). If inserting the cotter pin (31) is difficult, make sure handle (8) has been completely pressed onto the worm (4). Secure by bending ends of cotter pin (31) apart.

## Paying Out or Hauling In with Handle

(See Winch Assembly Drawing MHTPC0010)

When facing the housing assembly side of the winch:

Rotate the handle (8) clockwise to rotate the drum clockwise.

Rotate the handle (8) counterclockwise to rotate the drum counterclockwise.

To avoid "bird nesting" caused by slack wire rope, apply tension to the wire rope when spooling onto the drum.

## To Let Out Unloaded Wire Rope (Free-Spool Condition for Models W100-3, W100-6 and W200-5 Only)

(See Winch Assembly Drawing MHTPC0010)

### WARNING

• To avoid injury to personnel and damage to equipment due to a falling load, disconnect the load before disengaging the drum to free-spool.

1. Make sure there is no load on the winch.
2. Disengage the drum by lifting the free end of drum keeper (9), and pulling drum (5) off drum drive pin (12). Release keeper (9) to lock drum (5) in free-spool.
3. Pull end of wire rope to desired location.
4. Engage the drum by aligning the slot in drum (5) with drum drive pin (12). Lift keeper (9) to free drum (5) and press drum (5) onto drive pin (12). Release keeper (9).

### WARNING

• A creeping load can cause death or injury. Do not rely on the worm drive to hold a suspended load.

## Power Operation (For Models W100-3P, W100-6P and W200-5P Only)

### CAUTION

- Operating power units for time periods longer than suggested may result in damage to the winch.
- Never use power, other than manual, on winch models W100-3, W100-6 and W200-5.
- To avoid damage to the rigging, the structure supporting the rigging, and the winch, do not "two-block" the end of the wire rope.

Operate powered units no more than 10 minutes before stopping to allow the unit to cool to ambient temperature. Select a motor with a rated RPM less than the value listed below.

Model No.	Maximum Allowable Motor RPM	Maximum Line Speed	
		ft/min.	m/min.
W100-3P	320	10	3.1
W100-6P	320	10	3.1
W200-5P	315	11	3.4

Model No.	Rated Capacity on First Layer			
	Power Operation		Manual Operation	
	lb	kg	lb	kg
W100-3P	750	340	1500	681
W100-6P	750	340	1500	681
W200-5P	1500	681	3000	1363

## INSPECTION

There are two types of inspection, the frequent inspection performed by the operator and more thorough periodic inspections performed by qualified personnel.

### Frequent Inspection

On winches in continuous service, frequent inspection should be made at the beginning of each shift. In addition, visual observations should be conducted during regular service for any damage or evidence of malfunction.

1. **OPERATION.** To make sure the drive mechanism operates properly, check for sticking or other signs of malfunction. Repair if necessary. Test brake operation by lifting a load 2 to 3 in. (50 to 75 mm) off the floor and check that the brake holds the load.
2. **LIMIT DEVICES.** If used, check that they operate properly.
3. **WIRE ROPE.** Consult the wire rope manufacturer's inspection information or a recognized safety source, such as the latest edition of National Safety Council, Accident Prevention Manual for Industrial Operations or ANSI/ASME B30.7. Wire rope is a consumable item which must be replaced when worn. The following list is a guide to accepted standards by which wire rope must be judged and is not presented as a substitute for an experienced inspector.
  - a. Damage, such as: bird cages, kinking, core protrusion, crushing, heat damage, and main strand displacement.
  - b. Corrosion and nicking.
  - c. Wear of crown wires. Replace at 1/3 wear of the original diameter of any crown wire.
  - d. Broken wires or strands, particularly at connections. Replacement is necessary if one wire is broken at a connection; six broken wires within one lay; three broken wires in one strand within one lay.
  - e. Lubrication.Replace wire rope if any doubt exists as to wire rope serviceability.
4. **WIRE ROPE REEVING.** Check reeving and ensure wire rope is properly secured to the drum. Make sure the wire rope anchor screw is tight and check for signs of slippage of the wire rope end. If slippage is evident, reinstall per wire rope anchor installation procedure.

### Periodic Inspection

According to ANSI/ASME B30.7, frequency of periodic inspection depends on the severity of usage: **NORMAL**, yearly; **HEAVY**, semi-annually; **SEVERE**, quarterly. Disassembly may be required for **HEAVY** or **SEVERE** usage. Keep accumulative records of periodic inspections to provide a basis for continuing evaluation.

Inspect all items in "Frequent Inspection" also inspect the following:

1. **MEMBERS.** Check for deformed, cracked or corroded main components. Replace damaged parts if necessary.
2. **FASTENERS.** Check rivets, cotter pins, capscrews and nuts on winch, including mounting bolts. Replace if missing and tighten if loose.
3. **DRUM.** Check for cracks, wear or damage. Replace if necessary.
4. **ALL COMPONENTS.** Inspect for wear, damage, distortion and cleanliness. If external evidence indicates the need, for example poor performance or excessive noise, disassemble and inspect. Check pins, gears, shafts, bearings, sheaves, covers, etc. Replace worn or damaged parts.
5. **MOTOR.** Can only be used with W100-3P, W100-6P and W200-5P winches. Make sure it operates properly and conforms to applicable specifications. Inspect motor in accordance with motor manufactures inspection procedures.
6. **DRAG BRAKE.** Older versions of the W100-3P, W100-6P and W200-5P winches are equipped with an external drag brake. If parts become worn or load slippage occurs, install update kit M19898 for W100 winches and M19899 for W200 winches. Refer to Maintenance Section for installation instructions.
7. **SUPPORTING STRUCTURE.** Check for distortion, wear and continued ability to support the winch and load.
8. **LABELS AND TAGS.** Check for presence and legibility. Replace if necessary.
9. **WIRE ROPE.** Besides the items in a frequent inspection, inspect the following:
  - a. Loose or damaged connections to wire rope. Check for build-up of dirt and corrosion. Clean if necessary.
  - b. Check for changes in the size of the wire rope diameter. Measure the diameter from crown-to-crown. If the nominal diameter of the wire rope has decreased more than 1/64 in. (0.4 mm), replace the wire rope. See Dwg. MHTPA0056

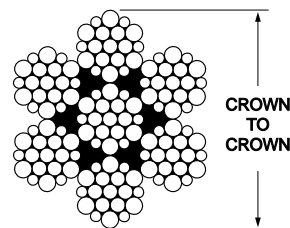

(Dwg. MHTPA0056)



- Never use a winch that inspection indicates is defective.

## Winches Not in Regular Use

A winch which has been idle for a period of one month or more, but less than six months, shall be given an inspection conforming with the requirements of "Frequent Inspection" before being placed into service.

A winch which has been idle for a period of over six months shall be given a complete inspection conforming with the requirements of "Periodic Inspection". Standby winches shall be inspected at least semi-annually in accordance with the requirements of "Frequent Inspection". If abnormal operating conditions apply winches may require a more frequent inspection.

## Testing

### Operational Tests

Prior to initial use, all new, altered or repaired winches shall be tested to ensure proper operation.

- a) Operate winch in both directions with no load.
- b) Check operation of clutch, brakes, and pawls.
- c) Check operation of limit switches, and locking or safety devices when provided.
- d) Check all tie-downs are secure.

### Load Test

Prior to initial use, all new, extensively repaired, or altered winches shall be load tested by or under the direction of a qualified person, and a written report furnished confirming the rating of the winch. Test loads shall not be more than 110% of the rated line pull.

## LUBRICATION

### WARNING

• **Lubricate the winch regularly using only the recommended grease in the housing assembly. Using oil or friction reducing additives in the housing assembly will cause "overrunning" of the winch resulting in the load not stopping. See "Enclosed Gears" below.**

### Enclosed Gears

(See Winch Assembly Drawing MHTPC0010)

If grease leaks out during usage of powered units, add more grease through the grease fitting (29) or housing plug (25) on the top of the housing. Adding grease is normally not necessary for manual powered units. However, check periodically for leakage and add grease if necessary. If housing assembly is disassembled, clean thoroughly and fill with new grease. Use enough grease to fill the lower housing with the winch completely assembled. For the Model W100, use 1/5 pint (89 ml) and the the model W200 use 1/2 pint (237 ml). For temperatures -20degrees to 50degrees F (-29degrees to 10 degrees C) use a multipurpose lithium-based EP 1 grease. For temperatures 30degrees to 120degrees F (-1degrees to 49degrees C) use a multi-purpose lithium-based EP 2 grease.

### Wire Rope

Follow the wire rope manufacturer's instructions. At a minimum, observe the following guidelines.

### CAUTION

• **Do not use an acid-based solvent. Only use cleaning fluids specified by the wire rope manufacturer.**

1. If there is dirt, rock dust or other foreign material on the surface of the wire rope, clean with a brush or steam.
2. Apply a wire rope lubricant or SAE 30 W oil.
3. Brush, drip or spray lubricant weekly, or more frequently, depending on severity of service.

## MAINTENANCE

### CAUTION

• **Before performing maintenance, disconnect the load from the winch. A falling load could cause death, injury or property damage.**

• **On powered units, disconnect the power source before performing any maintenance. Accidental operation or contact with exposed power supply could cause death, injury or property damage.**

When performing any maintenance:

1. Before starting maintenance, tag winch: DANGER-DO NOT OPERATE - EQUIPMENT BEING REPAIRED.
2. Only allow qualified service personnel to perform maintenance.
3. After performing maintenance on load bearing parts, test unit to 110% of its rated capacity before returning to service.

## Maintenance for Models W100-3, W100-6 and W200-5

(See Winch Assembly Drawing MHTPC0010)

The following maintenance instructions should be performed with the winch removed from its mounting structure.

### Gear Housing Removal (W100-3, W100-6 and W200-5)

1. Remove handle (8)



• To avoid damaging the gearing, ensure dirt or other contaminants do not enter the housing assembly when frame bolts (24) are removed.

2. Turn the winch on its side and remove the two frame bolts (24) from housing assembly (1). Then rest winch back on frame (6).
3. Remove housing assembly by moving it back and forth and pulling it away from drum (5).
4. Remove drum (5).
5. Only remove drum shaft bearing (7) if it is going to be replaced. To remove bearing (7), remove retaining ring (18). While holding drum keeper (9) out of the way, press out bearing (7).

### Gear Housing Disassembly (W100-3, W100-6 and W200-5)

1. While keeping housing nuts (27) from rotating, unscrew housing bolts (22). On W200-5, also remove housing bolt (30) with nut (27). Drive out housing dowels (21).
2. Remove drive pin (20), used with handle (8), from the worm shaft.
3. Pull or pry housing assembly (1) apart. If necessary, tap lightly with a rubber mallet to start.
4. Remove worm gear and shaft assembly (3).
5. Remove worm and shaft assembly (4). If necessary, tap lightly with a rubber mallet to free from lower housing.
6. Remove worm thrust bearing (16) from worm shaft (4). Remove second worm thrust bearing (16) from lower housing.
7. Press worm bushings (17) out of upper and lower housings.

### NOTICE

• Worm gear and worm gear shaft are sold as a matched set with worm gear drive pin (15) installed. Worm and worm shaft are also sold as a matched set, with worm drive pin (20) installed. Do not disassemble either the worm and shaft assembly (4) or the worm gear and shaft assembly (3). Replace only the complete assemblies.

## Gear Housing Assembly (W100-3, W100-6 and W200-5)

1. Remove old gasket material from machined surface of housings (1).
2. Clean old grease out of housings (1).
3. Press worm bushings (17) into housings (1). Leave lip of bushings (17) sticking out, on the inside of the housings (1), to retain worm thrust bearings (16).
4. Place one of the two thrust bearings (16) over the lip of bushing (17) in the lower housing.
5. Install the worm shaft (4) so that the long handle is up. Press lower end of worm shaft (4) into lower housing (1). If the fit between worm shaft (4) and either bushing (17) is extremely tight, it may be necessary to lightly hone the interior of bushing (17).
6. Place the worm gear shaft (3) so that it sticks out the left side of the housing assembly (1) when facing the worm shaft (4) end of the housing. Insert the worm and shaft assembly (4) into the lower housing (1). Rotate the worm and worm shaft assembly (4), if necessary, to mate the worm and worm gear. If a new worm gear and shaft assembly (3) is used, install a drum drive pin (12).
7. Place second thrust bearing (16) over the worm shaft (4).
8. Apply Locite 515 to the machined surface of lower housing (1).
9. Press upper housing (1) down over the end of the worm shaft (4).
10. Install housing bolts (22) and housing nuts (27). On W200-5, install housing bolt (30) with nut (27).
11. Install drive pin (20), used with handle (8), through the second hole from the top of the worm shaft (4).
12. Install housing dowels (21). Replace housing dowels (21) if damaged. If a new housing (1) is used, it may be necessary to drill out holes in the new housing for the housing dowels (21). Use the undamaged housing half that will be reused as a guide. Be careful not to enlarge the diameter of the holes.
13. Use grease fitting (29) or remove housing plug (25) and fill housing assembly (1) with grease. See "Enclosed Gears" under "LUBRICATION" for proper grease.

### Gear Housing Installation(W100-3, W100-6 and W200-5)

1. If necessary, install a new drum shaft bearing (7). Position bearing (7) so that the retaining ring groove will be "outside" frame (6). Align tab on bearing (7) with notch in frame (6). While holding keeper (9) out of the way, press in bearing (7). Secure by installing retaining ring (18).
2. Insert the long narrow shaft on the drum (5) through bearing (7) until drum (5) contacts keeper (9). If the drum shaft will not fully seat, rest the winch on housing assembly (1) and, with a rubber mallet, gently hammer on frame (6). Do not hammer on bearing (7). If necessary, lightly hone bearing (7).

3. Rotate drum (5) until drum shaft slot aligns with drum drive pin (12) on housing assembly (1).
4. Moving it back and forth if necessary, push housing assembly (1) towards drum (5) until pin (12) fits in drum shaft slot.
5. Align the bolt holes in frame (6) and housing assembly (1). Secure housing assembly (1) to frame (6) with frame bolts (24).

### Drum Keeper Replacement (W100-3, W100-6 and W200-5)

The drum keeper (9) can be removed without removing the drum (5). Keeper push nuts (19) should be pried off carefully. Note orientation of push nuts (19). When installing push nuts (19), hold the keeper (9) against the frame (6) by inserting a pry bar between the keeper (9) and the drum (5). Make sure the concave face of the push nuts (19) is towards the frame (6). Use a socket large enough to fit over the keeper pin and tap lightly.

### Maintenance for Models (W100-3P, W100-6P and W200-5P)

(See Winch Assembly Drawing MHTPC0010)

### Gear Housing Removal (W100-3P, W100-6P and W200-5P)

#### NOTICE

• Do not attempt to repair or adjust winches equipped with an adjustable external drag brake. Order and install update kit 'M19898' for the model W100 winch and kit 'M19899' for the model W200 winch.

1. Remove handle (8).
2. Rotate drum (5) until pin (12) is about 30 degrees from vertical. Using a large punch, drive out pin (12).

#### CAUTION

• To avoid damaging the gearing, ensure dirt or other contaminants do not enter the housing assembly (1) when frame bolts (24) are removed.

3. Turn the winch on its side and remove the two frame bolts (24) from housing assembly (1). Then rest winch back on frame (6).
4. Remove housing assembly (1) by moving it back and forth and pulling it away from drum (5). If necessary, tap housing assembly (1) with a rubber mallet.
5. Remove drum (5) from drum shaft (3).
6. Only remove drum shaft bearing (7) if it is going to be replaced. To remove bearing (7), remove retaining ring (18). Press out bearing (7).

### Gear Housing Disassembly (W100-3P, W100-6P and W200-5P)

1. While keeping housing nuts (27) from rotating, unscrew housing bolts (22). On W200-5P, also remove housing bolt (30) with nut (27). Drive out housing dowels (21).
2. Remove drive pin (20), used with handle (8), from the worm shaft.
3. Pull or pry housing assembly (1) apart. If necessary, tap lightly with a rubber mallet to start.
4. Remove worm gear and shaft assembly (3).
5. Remove worm and shaft assembly (4). If necessary, tap lightly with a rubber mallet to free from lower housing.
6. If necessary, press worm roller bearings (14) out of housings (1) and press worm bearing adapters (13) out of bearings (14). Remove 'O' ring (35).
7. On W200-5P, remove worm gear shaft bearings (23) from housings (1) or from worm gear shaft (3).

#### NOTICE

• Worm gear and worm gear shaft are sold as a matched set with worm gear drive pin (15) installed. Worm and worm shaft are also sold as a matched set, with worm drive pin (20) installed. Do not disassemble either the worm and shaft assembly (4) or the worm gear and shaft assembly (3). Replace only the complete assemblies.

### Gear Housing Assembly (W100-3P, W100-6P and W200-5P)

1. Remove old gasket material from machined surface of housings (1).
2. Clean old grease out of housings (1).
3. Press worm bearing adapter (13) into worm roller bearings (14), if necessary. Partially install worm roller bearings (14) into housings (1), pressing on the outer race only.
4. Slide 'O' rings (35) all the way through the bore of worm bearing adapters (13) until they are positioned between the housings (1) and the inner race of bearings (14). Center the 'O' rings (35) under bearing and press the worm roller bearing (14) and adapters (13) completely into housings (1) until they are fully seated.
5. Install the worm shaft (4) so that the long handle is up. Press lower end of worm shaft (4) into lower housing (1) being careful not to damage 'O' ring (35). Press on the inner race of the bearing only. If the fit between worm shaft (4) and either adapter (13) is extremely tight, it may be necessary to lightly hone adapter (13).
6. On W200-5P, install both worm gear shaft bearings (23) on worm gear shaft (3), one on each side of the worm gear (3).

7. Place the worm gear shaft (3) so that it sticks out the left side of the housing assembly (1) when facing the worm shaft (4) end of the housing. Insert the worm and shaft assembly (4) into the lower housing (1). Rotate the worm and worm shaft assembly (4), if necessary, to mate the worm (4) and worm gear (3).
8. Apply Locite 515 to the machined surface of lower housing (1).
9. Press upper housing (1) down over the end of the worm shaft (4) being careful not to damage the 'O' ring (35).
10. Install housing bolts (22) and housing nuts (27). On W200-5P, install housing bolt (30) with nut (27).
11. Install housing dowels (21). Replace housing dowels (21) if damaged. If a new housing (1) is used, it may be necessary to drill out holes in the new housing for the housing dowels (21). Use the undamaged housing half that will be reused as a guide. Be careful not to enlarge the diameter of the holes.
12. Use grease fitting (29) or remove housing plug (25) and fill housing assembly (1) with grease. See "Enclosed Gears" under "LUBRICATION" for proper grease.

### Gear Housing Installation(W100-3P, W100-6P and W200-5P)

1. If necessary, install a new drum shaft bearing (7). Position bearing (7) so that the retaining ring groove will be "outside" frame (6). Align tab on bearing (7) with notch in frame (6). Press in bearing (7). Secure by installing retaining ring (18).
2. Place the drum (5) so that the hole for the drum drive pin (12) is towards the housing assembly (1). Slide the drum (5) over the worm gear shaft (3).
3. Rotate worm gear shaft (3) until the hole for pin (12) is about 30 degrees from vertical. Align the holes in the drum (5) and worm gear shaft (3). Install drum drive pin (12).
4. Position housing assembly (1) with drum (5) on the frame (6). Moving it back and forth if necessary, push the end of the worm gear shaft (3) into drum shaft bearing (7). If the worm gear shaft (3) does not fully seat, rest the winch on housing assembly (1) and, with a rubber mallet, gently hammer, on frame (6). Do not hammer on bearing (7). If necessary, lightly hone bearing (7).
5. Align the bolt holes in frame (6) and housing assembly (1). Secure housing assembly (1) to frame (6) with frame bolts (24).

### Maintenance for (W100-3P, W100-6P and W200-5P)

#### NOTICE

- This section only applies to older style winches. The current winch design does not include an adjustable drag brake package.
- Reference Drawing MHTPC0109 is only provided to assist with brake disc removal so an update kit can be installed.

### Brake Disc Removal (W100-3P, W100-6P and W200-5P Only)

(See Drawing MHTPC0109)

1. If not already installed, install handle (8) on worm shaft (4).
2. Use handle (8) to keep the worm shaft (4) from moving and loosen adjusting nut (37).
3. Remove handle (8) and drive out drive pin (20) with a hammer and punch.
4. Remove adjusting nut (37) and two belleville springs (38). Remove brake plate (39) from worm shaft (4).
5. Drive out drive pin (42) with a hammer and punch. Remove sleeve (41).
6. Remove brake disc (40).

#### Discard the following parts:

ITEM NO.	DESCRIPTION OF PART	QTY. TOTAL
37	Adjusting Nut	1
38	Belleville Spring	2
39	Brake Plate	1
40	Brake Disc	1
41	Sleeve	1
42	Drive Pin	1

Install update kit 'M19898' in model W100 winches and 'M19899' in model W200 winches. Follow disassembly and assembly procedures detailed in "Maintenance for models W100-3P, W100-6P and W200-5P".

Model W100 Update Kit 'M19898' consists of:

Qty	Description	Part No.
2	Bearing	19188
2	'O' ring	71049423

Model W200 Update Kit 'M19899' consists of:

Qty	Description	Part No.
2	Bearing	18938
2	'O' ring	71049324

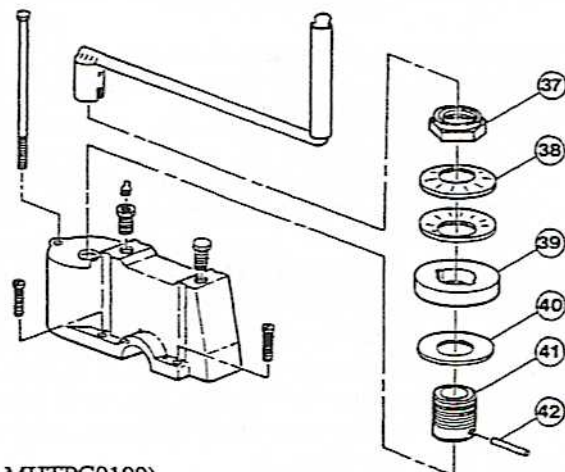

(Dwg. MHTPC0109)

W100 AND W200 SERIES WINCH ASSEMBLY

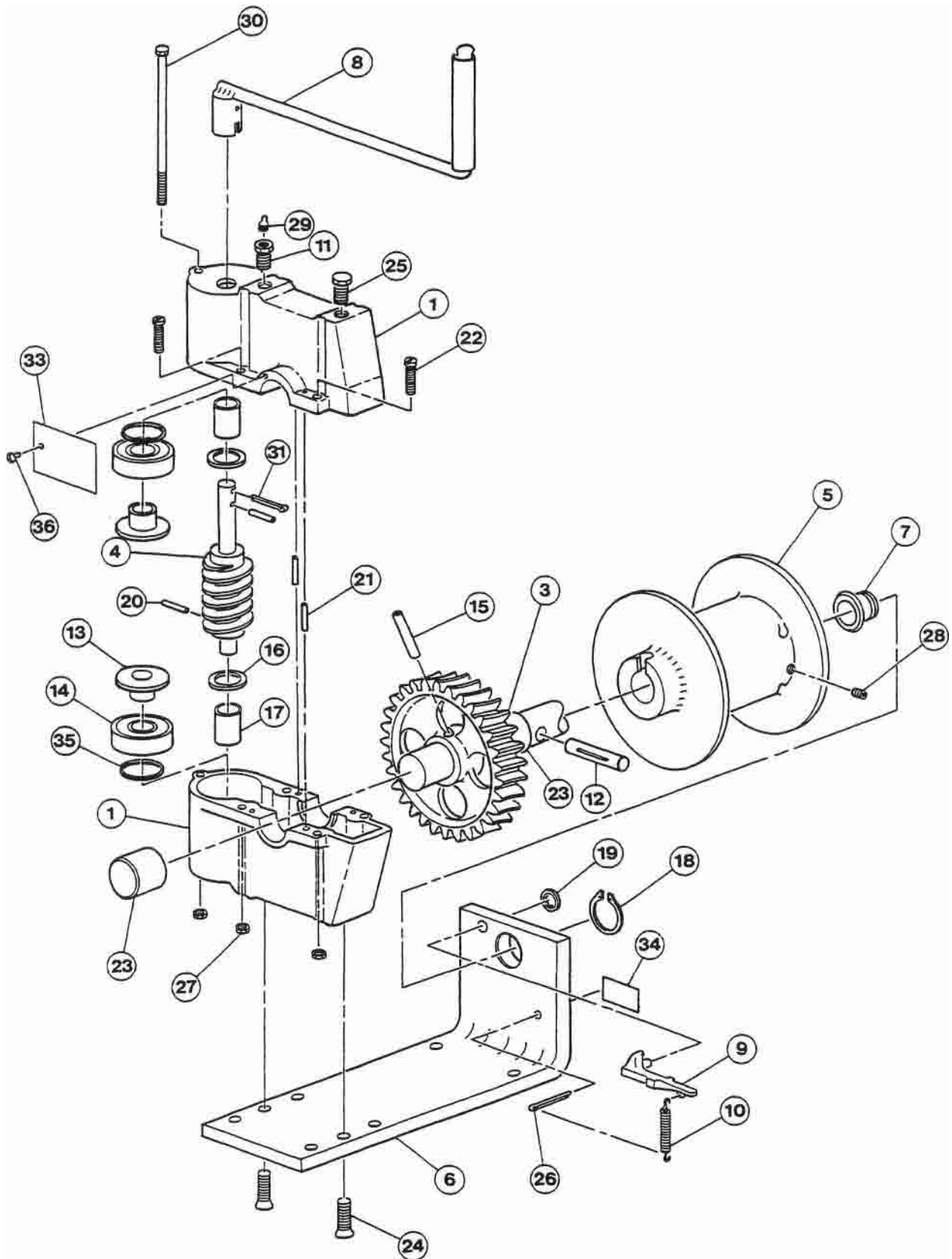

## W100 AND W200 SERIES WINCH PARTS LIST

ITEM	DESCRIPTION OF PART	QTY	PART NUMBER					
			W100-3	W100-6	W100-3P	W100-6P	W200-5	W200-5P
1	Housing	2	850		2729		872	2744
3	Worm Gear and Shaft Assy. (Includes Item 15)	1	851-1		851-2	851-3	867-1	867-2
4	Worm and Shaft Assy. (Includes Item 20)(Qty 1)	1	3013-1		3013-2		2983-2	
5	Drum	1	857-1	857-2	858-1P	858-2P	869	4905
6	Frame	1	3012	3011	3012	3011	2978	
•7	Drum Shaft Bearing	1	2982					
•8	Handle Assy. (Includes	1	863-1				863-2	
•9	Drum Keeper	1	2981-1		—		2981-2	—
•10	Drum Keeper Spring	1	8037		—		8037	—
11	RllPlug	1	—				4500	
12	Drum Drive Pin	1	71051197		53480		8057	53982
13	Worm Bearing Adapter	2	—		19188		—	18938
14	Worm Roller Bearing	2	—		50841		—	52004
•15	Worm Gear Drive Pin	1	53480				53982	
•16	Worm Thrust Bearing	2	50266		—		51215	—
17	Worm Bushing	2	51588		—		51216	—
18	Retaining Ring	1	51398					
19	Keeper Push Nut	2	51829		—		51829	—
20	Worm Drive Pin	2	71001135				52332	
21	Housing Dowel	2	54257					
22	Housing Bolt	4	55044					
•23	Worm Gear Shaft	2	—					52003
24	Frame Bolt	2	51815				71048169	
25	Housing Plug	2	54654				71048177	
26	Cotter Pin	1	71051189		—		7105118	—
27	Housing Nut	4/5	50161 (4)				50161 (5)	
28	Cable Anchor Screw	1	52643				50855	
29	Grease Fitting	1	—				53496	
30	Housing Bolt	1	—				53981	
31	Cotter Pin	1	54590					
33	Warning Tag	1	71056410					
34	Model Label	1	71064208					
35	'O'Ring	2	—		71049423		—	71049324
•36	Drive Screw	1	50915					
37	O&MManual	1	Form No. MHD56007					

• Recommended spare

## PARTS ORDERING INFORMATION

The use of other than **Wintech International** replacement parts may damage or impair the operation of this winch. For your convenience and future reference it is recommended that the following information be recorded.

Model Number: \_\_\_\_\_

Serial Numbers

Winch: \_\_\_\_\_

Motor: \_\_\_\_\_

Brake: \_\_\_\_\_

Date Purchased: \_\_\_\_\_

When ordering replacement parts, please specify the following:

1. Complete model number and serial number(s) as they appear on the nameplates.
2. Part number(s) and part description as shown in this manual.
3. Quantity required.

The winch nameplate is located on the side frame. The motor nameplate is located on the motor housing, and the brake nameplate is located on the brake housing.

If a nameplate is not attached to your unit, order a new nameplate and install it. See the parts list for the part numbers.

### NOTICE

• **Continuing improvement and advancement of design may cause changes to this equipment which are not included in this manual. Manuals are periodically revised to incorporate changes. Always check the manual edition number on the front cover for the latest issue.**

### Return Goods Policy

**WINTECH International** will not accept any returned goods for warranty or service work unless prior arrangements have been made and written authorization has been provided from the location where the goods were purchased.

When the life of the unit has expired, it is recommended that it be disassembled, degreased and parts separated as to materials so that they may be recycled.

For additional information contact:

**Wintech International Inc.**  
**5319 Shreveport/Blanchard Hwy.**  
**Shreveport, LA. 71107**

**Phone: (318) 929-1242**  
**1-888-946-8325**

**Fax: (318) 929-1245**

## HOIST AND WINCH LIMITED WARRANTY

**Wintech International** warrants to the original user of its Hoists and Winches (Products) to be free of defects in material and workmanship for a period of one year from the date of purchase. **WİNTECH** will repair, without cost, any Product found to be defective, including parts and labor charges, or at its option, will replace such Products or refund the purchase price less a reasonable allowance for depreciation, in exchange for the Product. Repairs or replacements are warranted for the remainder of the original warranty period.

If any Product proves defective within its original one year warranty period, it should be returned to any Authorized Hoist and Winch Service Distributor, transportation prepaid with proof of purchase or warranty card.

This warranty does not apply to Products which **WİNTECH** has determined to have been misused or abused, improperly maintained by the user, or where the malfunction or defect can be attributed to the use of non-genuine **WİNTECH** parts.

**Wintech makes no other warranty, and all implied warranties including any warranty of merchantability or fitness for a particular purpose are limited to the duration of the expressed warranty period as set forth above. WİNTECH's maximum liability is limited to the purchase price of the Product and in no event shall WİNTECH be liable for any consequential, indirect, incidental, or special damages of any nature rising from the sale or use of the Product, whether based on contract, tort, or otherwise.**

**Note:** Some states do not allow limitations on incidental or consequential damages or how long an implied warranty lasts so that the above limitations may not apply to you.

This warranty gives you specific legal rights and you may also have other rights which may vary from state to state.

## IMPORTANT NOTICE

It is our policy to promote safe delivery of all orders.

This shipment has been thoroughly checked, packed and inspected before leaving our plant and receipt for it in good condition has been received from the carrier. Any loss or damage which occurs to this shipment while enroute is not due to any action or conduct of the manufacturer.

### **Visible Loss or Damage**

If any of the goods called for on the bill of lading or express receipt are damaged or the quantity is short, do not accept them until the freight or express agent makes an appropriate notation on your freight bill or express receipt.

### **Concealed Loss or Damage**

When a shipment has been delivered to you in apparent good condition, but upon opening the

crate or container, loss or damage has taken place while in transit, notify the carrier's agent immediately.

### **Damage Claims**

You must file claims for damage with the carrier. It is the transportation company's responsibility to reimburse you for repair or replacement of goods damaged in shipment. Claims for loss or damage in shipment must not be deducted from the **Wintech International** invoice, nor should payment of **Wintech International** invoice be withheld awaiting adjustment of such claims as the carrier guarantees safe delivery.

You may return products damaged in shipment to us for repair, which services will be for your account and form your basis for claim against the carrier.



## **United States Office Location**

**For Order Entry, Order Status, and  
Technical Support:**

**Wintech International, L.L.C.  
5301 Shreveport/Blanchard Hwy.  
Shreveport, LA. 71107**

**Phone: (318) 929-1242  
1-888-946-8325  
Fax: (318) 929-1245  
[www.wintech-winch.com](http://www.wintech-winch.com)**

